

Certificate of Analysis

NGA2 Glycan (A2)

Cat. #: CN-NGA2-20U (2*10U) / CN-NGA2-10U

Batch: B144-03

Size: 20µg (2*10 µg) / 10µg

Alternative Names

A2

Structure

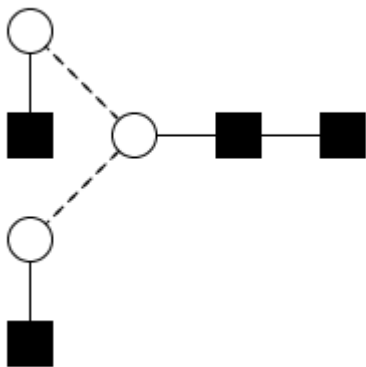

Oxford Notation

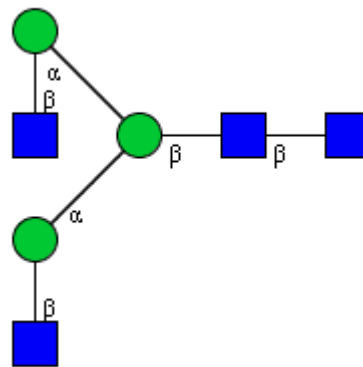

CFG Notation

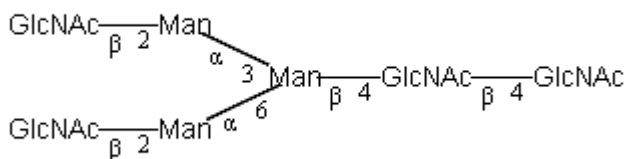

Text Notation

Purity: > 90% pure as assessed by a combination of HPAE-PAD (see Fig 1) and N2 HPLC (see Fig 3).

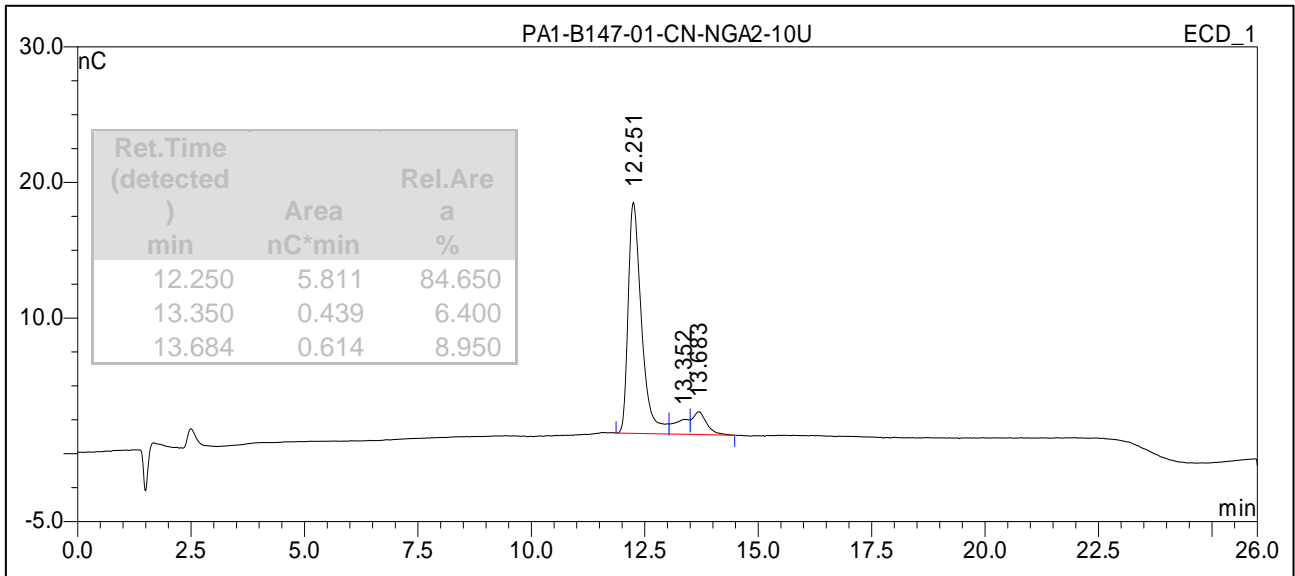

Figure 1 : HPAE-PAD HPLC Profile of NGA2 (CN-NGA2-10U, Batch B144-03).

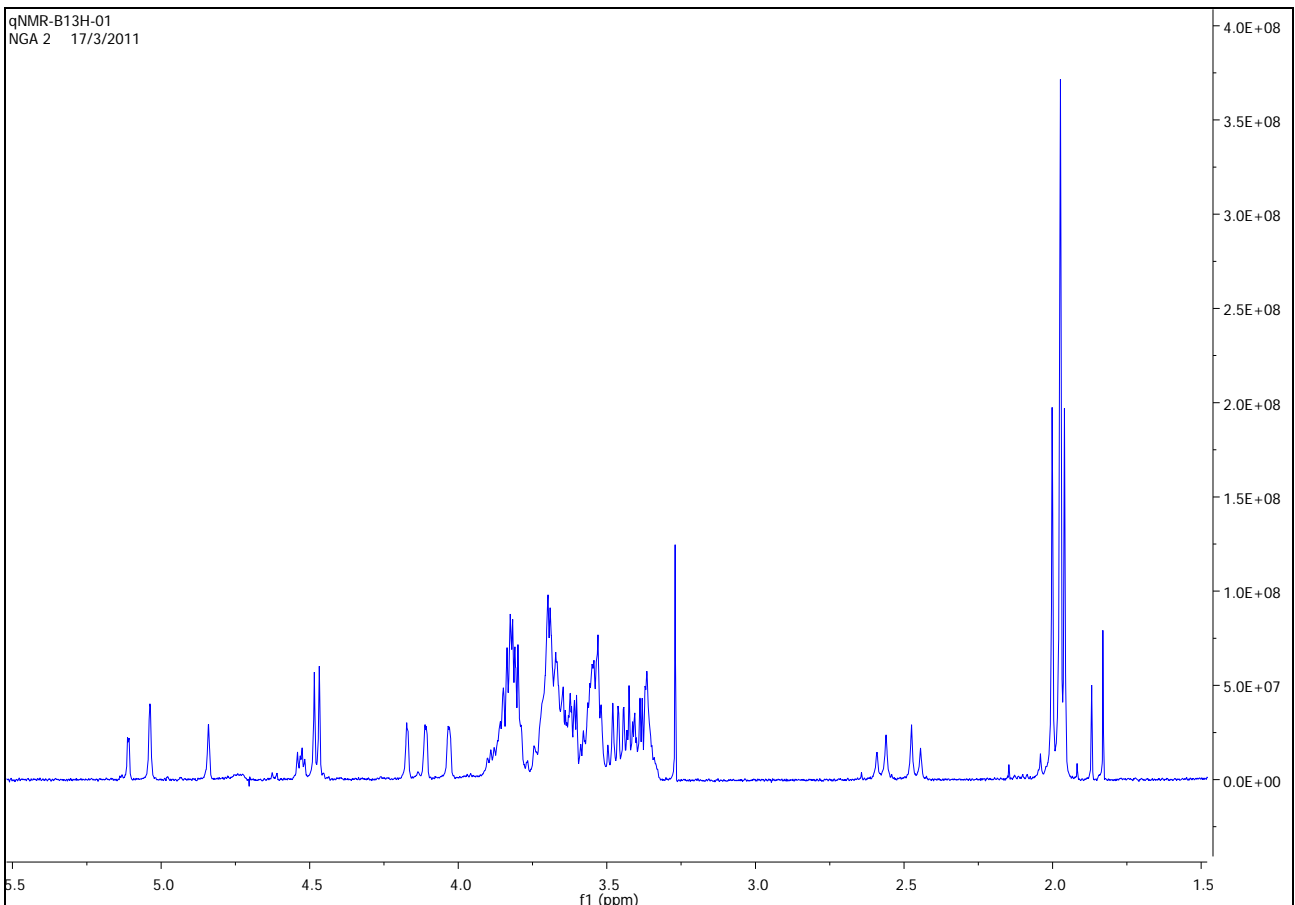

Figure 2: 500MHz ¹H-NMR of NGA2 glycan BULK (CN-NGA2-BULK Batch B148-12).

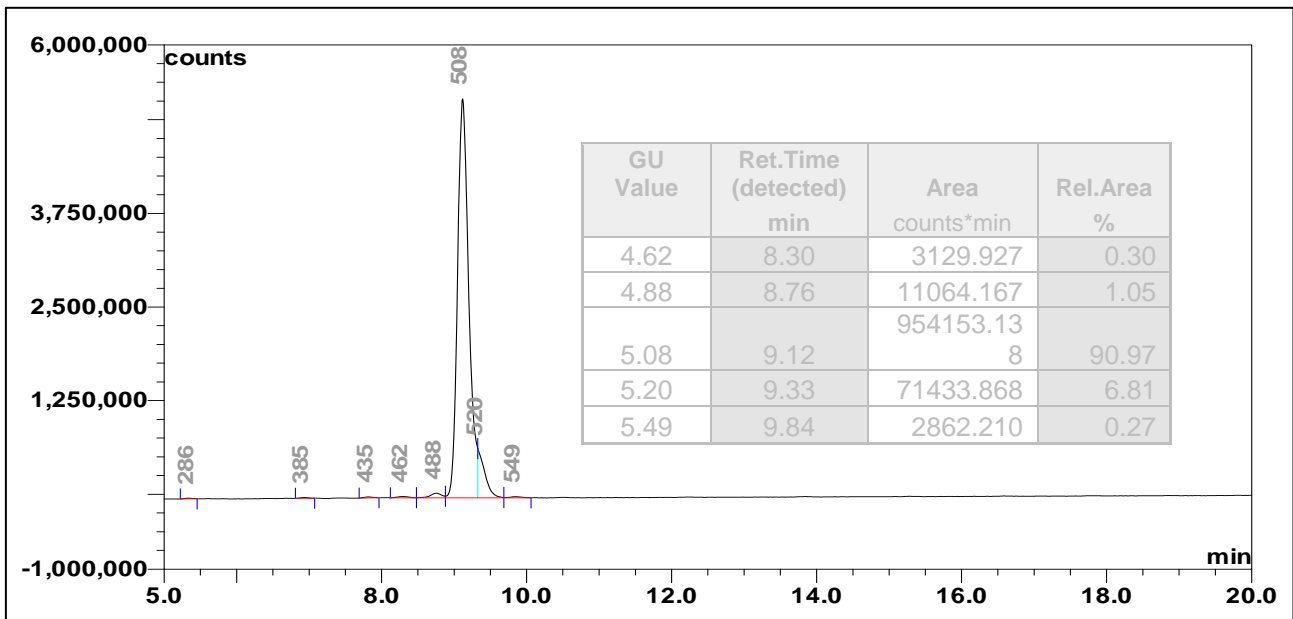

Figure 3: LudgerSepN2 chromatogram of 2AB labelled NGA2 glycan (CN-NGA2-10U, Batch B144-03).

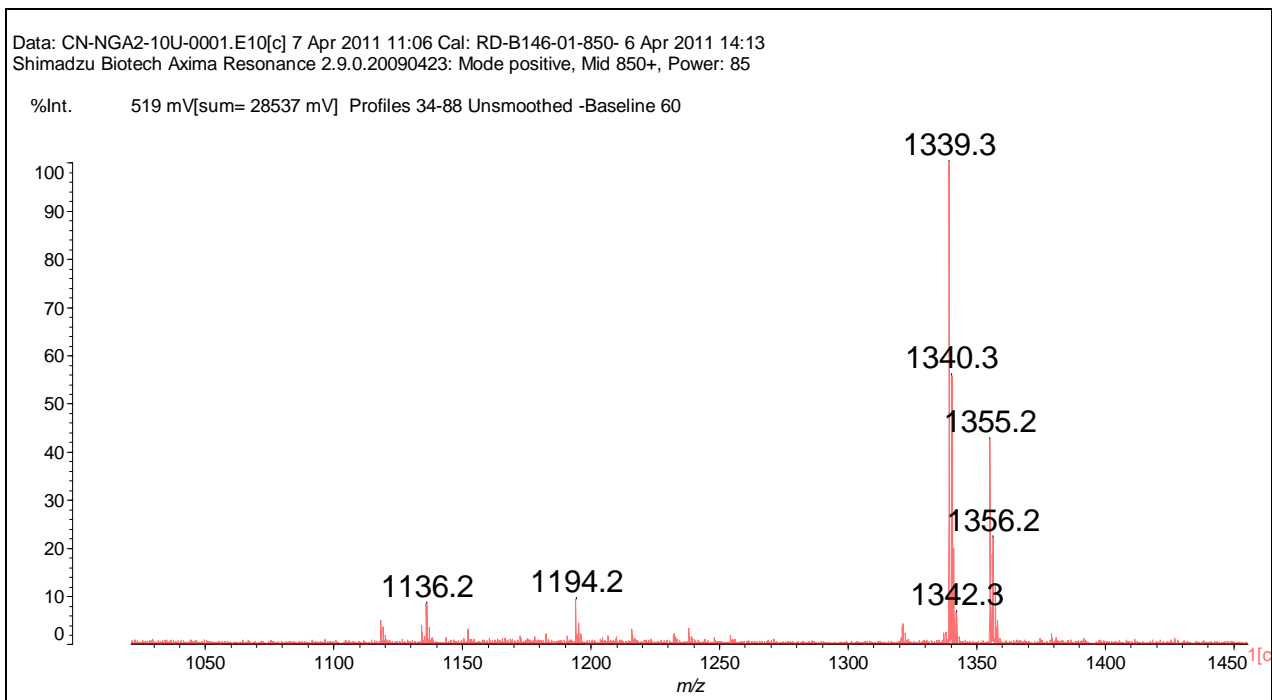

Figure 4: Positive ion mass spectrum of NGA2 glycan (CN-NGA2-10U, Batch B144-03). Theoretical mass 1339.5 Da [M+Na]⁺.